

# B300K

## Portable Power Station

### User Manual v1.0

Inspect the packaging for damage before use.

Perform a charge cycle before first use.

Scan the QR code for the BLUETTI app.

Register for warranty at <https://www.bluettipower.com/>

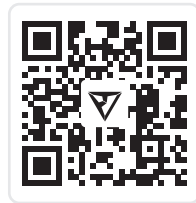

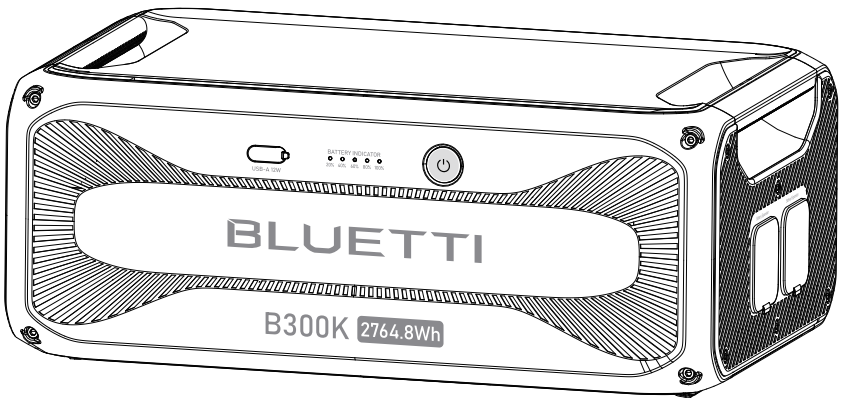

# Thank You

Thank you for making BLUETTI a part of your family.

From the very beginning, BLUETTI has tried to stay true to a sustainable future through green energy storage solutions while delivering an exceptional eco-friendly experience for our homes and our world.

That's why BLUETTI makes its presence in 100+ countries and is trusted by millions of customers across the globe.



**Copyright © Shenzhen PowerOak Newener Co., Ltd. All Rights Reserved.**

No reproduction or transmission of any part of this document is permitted without the prior written consent of Shenzhen PowerOak Newener Co., Ltd.

## Disclaimer

BLUETTI's products and services are subject to the terms and conditions agreed upon during purchase. Some aspects described in this manual may not be available under your purchase contract. Unless otherwise specified in the contract, BLUETTI makes no express or implied representations or warranties regarding the contents of this manual.

BLUETTI should assume no liability for the failures, damages, or injuries resulting from force majeure, repair attempts by unqualified personnel, or improper installation and operation.

The contents of this manual are subject to change without notice. Please obtain the latest version from BLUETTI official website.

If you have any questions or concerns about this manual, please contact BLUETTI support for further assistance.

**Shenzhen PowerOak Newener Co., Ltd.**

F19, BLD No.1, Kaidaer, Tongsha RD No.168, Xili street, Nanshan, Shenzhen, China

Web: <https://www.bluettipower.com>

# About the Manual

## Introduction

This manual provides information on the functionality, basic operation and safety instructions of the B300K portable power station. Please read and understand all instructions in this manual before use.

## Target Audience

- Technical support engineer
- End-user



# Contents

1	Safety Information .....	06
2	Packing List .....	08
3	Get to Know Your B300K .....	09
4	Use Your B300K .....	10
	Power On/Off .....	10
	Connect to B300K and Power Station .....	10
	Charge Up .....	13
	Control and Monitor .....	13
5	Indicators Status .....	14
6	Maintenance and Care .....	14
7	Specifications .....	15
8	Troubleshooting .....	16
	Appx. 1 FAQ (Frequently Asked Questions) .....	17
	Appx. 2 Compliance .....	18
	FCC Statement .....	18
	IC Caution .....	19
	CAN ICES-3 (B)/NMB-3(B) (Canada) .....	19
	Appx. 3 Consignes de sécurité .....	20

# 1. Safety Information

## General Safety

**WARNING** - When using the product, basic precautions should always be followed to prevent the risk of fire, electric shock, or injury to persons:

- Read all the instructions before using the product.
- Use and store the product in a cool, dry place with good ventilation.
- Keep it away from flammable liquids, gases, explosives and corrosive substances.
- Do not expose it to high temperatures or heat sources like sunlight, fire, transformers, and heaters.
- Do not insert fingers or foreign objects into the product's ports.
- Do not use damaged or modified product to prevent electric shock, injury, etc.
- Operate the product only with undamaged plugs and cables.
- Do not move the product during use to avoid internal hardware damage from vibration and collision.
- Handle the product with care to prevent drops, violent impacts, or tilting.
- Place the product on a stable platform.
- Keep the product out of reach of children and pets.
- Avoid submerging or cleaning the product with liquids.
- Power off the product before any servicing to reduce the risk of electric shock.
- Only professionals should handle leaks or defects - seek their assistance as needed.

## Battery Safety

- Use the battery within the specified temperature range.
- Do not disassemble, modify, or damage the battery to prevent leakage, overheating, or fire.
- Keep the positive and negative battery terminals from touching each other or metal objects.
- Avoid welding or grinding near batteries to prevent fire from sparks or arcs.
- Do not drop metal tools onto the battery to prevent sparks or short circuits.
- Lithium-ion batteries pose fire risks, so be aware of these hazards:
  - a. Thermal runaway can release flammable and harmful gases such as CO and HF. Vapors from burning batteries may irritate the eyes, skin, and throat.
  - b. The concentration of these gases could lead to deflagration and explosion.
  - c. The battery electrolyte is flammable, toxic, and volatile.
- If a battery leaks chemicals or emits odors, don't approach it - contact professionals for safe disposal. They'll need proper protective gear.
- Do not touch a battery that's been submerged in water, to avoid electric shocks. Discard soaked batteries through proper recycling channels.

- Electrolyte is corrosive and can cause irritation and chemical burns. If you come into direct contact with battery electrolyte:
  - a. Inhalation of Vapors: Evacuate the contaminated area, get fresh air immediately, and seek medical attention.
  - b. Eye Contact: Immediately flush eyes with water for at least 15 minutes, do not rub eyes, and seek medical attention immediately.
  - c. Skin Contact: Immediately wash the infected area with soap and water and seek medical attention immediately.
  - d. Ingestion: Seek medical attention immediately.
- Follow local guidelines for proper battery disposal; never burn, crush, or discard them improperly.

### **Personal Precautions**

- When working near batteries, wear eye and clothing protection.
- Avoid smoking, sparks, or flames near the battery or engine.
- In abusive conditions, liquid may eject. If contact occurs, flush with water; seek medical help if liquid contacts eyes.

SAVE THESE INSTRUCTIONS

## 2. Packing List

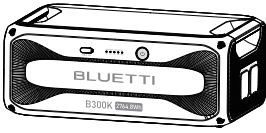

B300K

Portable Power Station

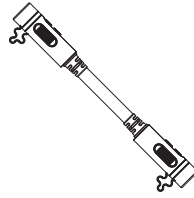

P090A

Battery Expansion Cable  
( 31.49in / 800mm )



Documentation

The following accessory may not be included. Please purchase optional accessories at <https://www.bluettipower.com>

### Optional Accessory

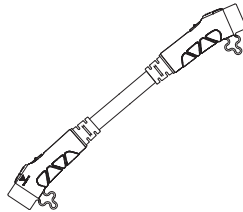

P090D to P150D Battery Expansion Cable  
( 31.49in / 800mm )

#### Note:

##### Battery Expansion Cables:

Connect the B300K to AC300, AC200MAX, AC200L, or other B300K units with the P090A battery expansion cable. Use the P090D to P150D cable to connect to AC500.

### 3. Get to Know Your B300K

The B300K can be used with AC300, AC500, AC200MAX, and AC200L as a 2,764.8Wh expansion pack.

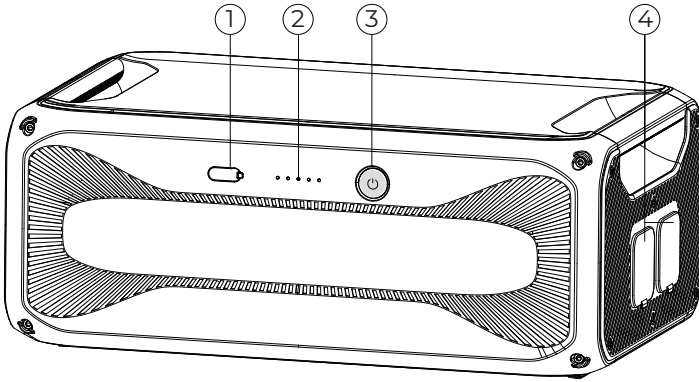

① USB-A Port

② LED Indicators\*

③ Power Button\*\*

④ Battery Expansion Ports

\* Indicate battery level and operation status.

\*\* Button light indicates operation status with LED indicators.

Refer to Chapter 5 (Indicators Status) and Chapter 8 (Troubleshooting) for details.

## 4. Use Your B300K

### Power On/Off

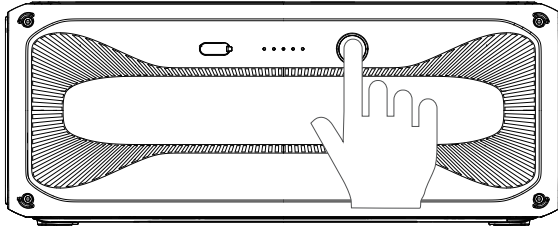

#### Power On

1. Long press the power button.
2. When the button lights up, the B300K is on standby.
3. The LED indicators show the battery level.

#### Power Off

1. Long press the power button.
2. The button light and indicators turn off.

**Note:** Connected to a power station, the B300K automatically turns on when the combo charges with AC power or solar panels.

### Connect to B300K and Power Station

#### Connecting to B300K Battery

Use the P090A battery expansion cable to interconnect the B300K units.

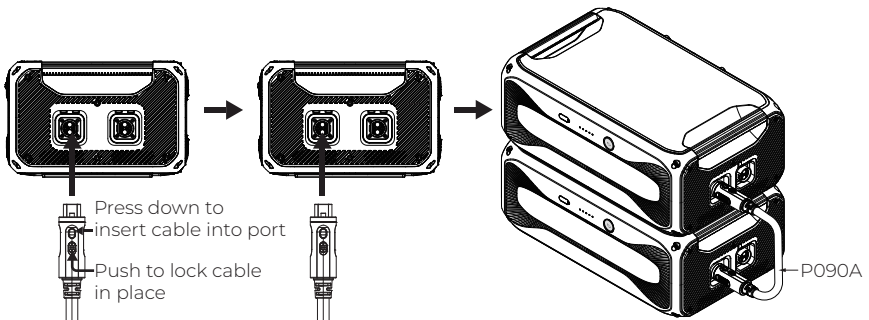

## Connecting to AC300

Connect up to 4 B300K units for a maximum capacity of 11,059.2Wh.

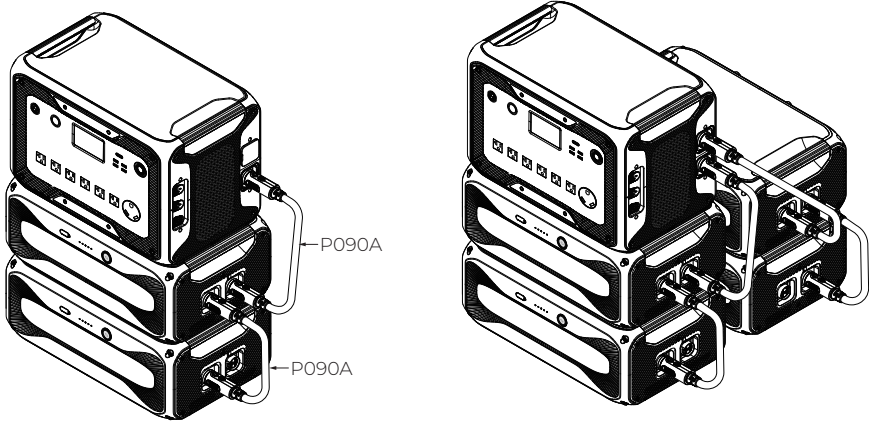

**Note:** The AC300 can work with B300K and B300 expansion batteries simultaneously using P090A battery expansion cables.

## Connecting to AC200MAX

Connect up to 2 B300K units for a maximum capacity of 7,577.6Wh.

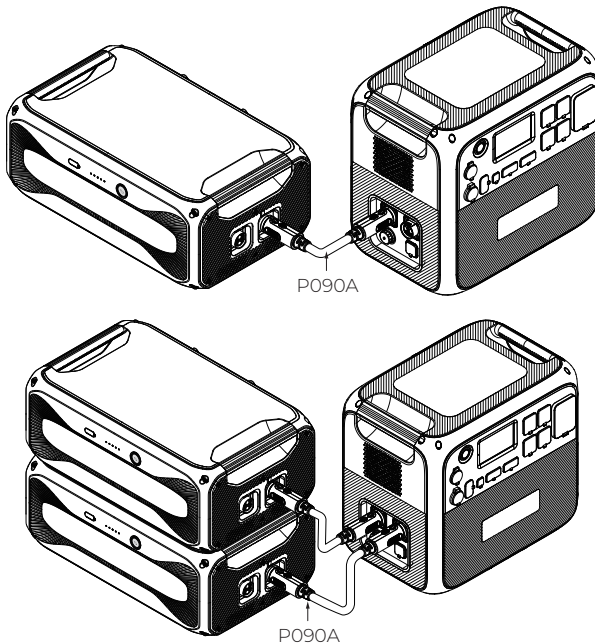

## Connecting to AC200L

Connect up to 2 B300K units for a maximum capacity of 7,577.6Wh.

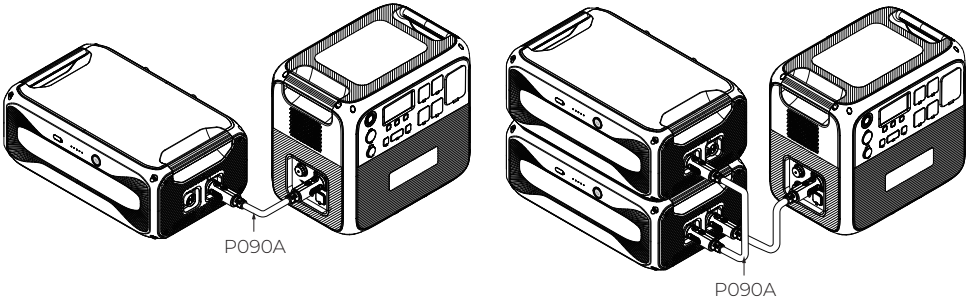

## Connecting to AC500

Connect up to 6 B300K units for a maximum capacity of 16,588.8Wh.

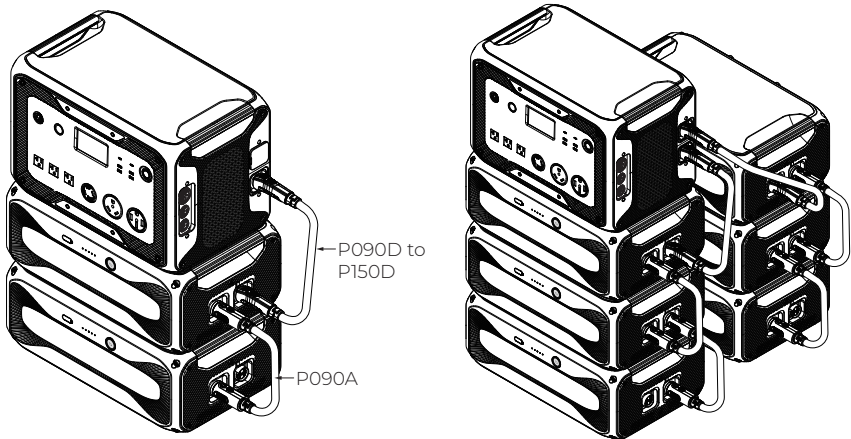

**Note:** The AC500 can work with B300K, B300S, and B300 expansion batteries simultaneously. To connect them:

Connection	Cable Required
AC500 to B300S	P150D battery expansion cable
AC500 to B300K/B300	P090D to P150D battery expansion cable
B300K/B300 to B300S	P090D to P150D battery expansion cable
B300K to B300	P090A battery expansion cable



## Charge Up

Connect the B300K to a power station for charging. It charges from 5% to 80% in about 45 minutes when connected to AC300 or AC500.

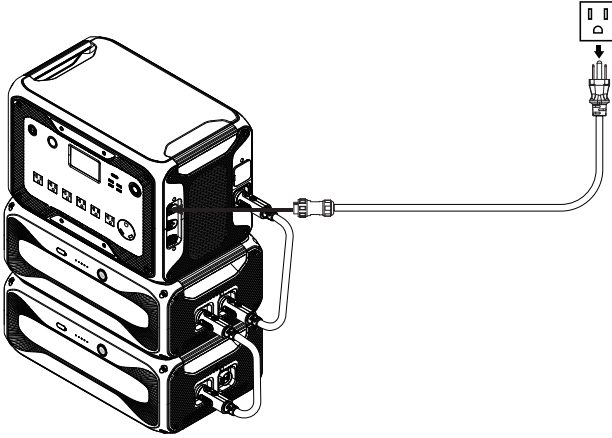

**Note:** Recommended charging temperature: 15°C to 30°C (59°F to 86°F)

## Control and Monitor

Connect the B300K to a power station, and check the battery level and upgrade it using the BLUETTI app. For more details, please refer to your power station's app user guide.

## 5. Indicators Status

Indicator	Status	Description
Power Button	Steady green	Normal operation
	Flashes 4 times per second	Malfunction
	Flashes once every 1.5 seconds	Upgrading
	Off	Shutdown
	Flashes twice, pause for 4 seconds, and repeat	The battery expansion cable is not locked.
LEDs	<ul style="list-style-type: none"><li>• Each lit indicator represents 20% SoC.</li><li>• All indicators remain steady when fully charged and go off when fully discharged.</li><li>• Flashing indicators show the charging progress.</li></ul>	

## 6. Maintenance and Care

- When the SoC drops to 1% without any power input, power off the unit promptly to prevent overdischarge.
- Before storing, charge it to 60%-80% SoC and fully cycle every 6 months to maintain battery health.
- For long-term storage over 6 months, charge it to 40%-60% SoC and fully cycle every 3 months.
- Safe storage temperature: -20°C to 40°C (-4°F to 104°F). For storage over a month, aim for a range of -20°C to 25°C (-4°F to 77°F). Perform a cycle charge before reuse.
- Avoid extended storage periods as it can impact the battery's performance and lifespan.
- Use a dry and soft towel to clean the battery's exterior.

## 7. Specifications

General	
Model	B300K
Battery Capacity	2,764.8Wh (51.2V, 54Ah)
Battery Type	LFP
Net Weight	Approx. 29.5kg (65.04lbs)
Dimensions (L × W × H)	525 × 327 × 209mm (20.67 × 12.87 × 8.23in)
Charging Temperature	0°C to 40°C (32°F to 104°F)
Discharging Temperature	-20°C to 40°C (-4°F to 104°F)
Storage Temperature	Up to 1 month: -20°C to 40°C (-4°F to 104°F) Up to 6 months: -20°C to 25°C (-4°F to 77°F)
Working Humidity	5% to 95%RH
Charging Current	60A Max. (Current may decrease outside specified temperatures)
Discharging Current	70A Max.
2 × Expansion Port	58.4VDC Max., 90A Max.
DC Output	
USB-A	12W Max., 5V / 2.4A

# 8. Troubleshooting

When the B300K malfunctions, the LEDs may flash or turn off in various combinations. For soft errors, restart the unit. For hardware issues, contact BLUETTI support for repair or replacement. See the table below for details.

Indicators Status	Description
<b>Soft Errors</b>	
☀ ● ● ● ●	Low voltage
● ☀ ● ● ●	High/low temperature
☀ ☀ ● ● ●	Pre-charge failure
● ● ☀ ● ●	Short circuit
☀ ● ☀ ● ●	Address allocation mix-up
● ☀ ☀ ● ●	Charging/discharging overcurrent
☀ ☀ ☀ ● ●	Overdischarging protection
<b>Hardware Failures</b>	
● ● ● ☀ ●	NTC fault
☀ ● ● ☀ ●	Cell fault
● ☀ ● ☀ ●	Voltage reference fault (3.3V)
☀ ☀ ● ☀ ●	AFE fault
● ● ☀ ☀ ●	Current zero point error
☀ ● ☀ ☀ ●	Battery cell disconnect
● ☀ ☀ ☀ ●	Charging MOS fault
☀ ☀ ☀ ☀ ●	Discharging MOS fault
● ● ● ● ☀	Cell voltage difference fault
☀ ● ● ● ☀	Current detection error

## Appx. 1 FAQ (Frequently Asked Questions)

**Q1:** How to claim warranty?

**A:** Please refer to the warranty card.

**Q2:** How to upgrade the B300K?

**A:** Connect the B300K to the power station and upgrade it via the BLUETTI app in Settings > Firmware Upgrade. Follow in-app instructions.

**Q3:** Can it charge and discharge at the same time?

**A:** Yes, the B300K supports pass-through charging.

**Q4:** Why doesn't the B300K drain all its power?

**A:** The B300K reserves some energy to avoid overdischarging and protect the battery's lifespan.

**Q5:** Can I leave the battery uncharged after fully discharging?

**A:** No, charge promptly after use to prevent damage. Keep the battery in the environment of at least 10°C (50°F) for at least 12 hours beforehand.

## Appx. 2 Compliance

### FCC Statement

This device complies with part 15 of the FCC Rules. Operation is subject to the following two conditions:

- (1) This device may not cause harmful interference.
- (2) This device must accept any interference received, including interference that may cause undesired operation.

This equipment has been tested and found to comply with the limits for a Class B digital device, pursuant to part 15 of the FCC Rules. These limits are designed to provide reasonable protection against harmful interference in a residential installation. This equipment generates, uses and can radiate radio frequency energy and, if not installed and used in accordance with the instructions, may cause harmful interference to radio communications. However, there is no guarantee that interference will not occur in a particular installation. If this equipment does cause harmful interference to radio or television reception, which can be determined by turning the equipment off and on, the user is encouraged to try to correct the interference by one or more of the following measures:

- Reorient or relocate the receiving antenna.
- Increase the separation between the equipment and receiver.
- Connect the equipment into an outlet on a circuit different from that to which the receiver is connected.
- Consult the dealer or an experienced radio/TV technician for help.

**FCC Caution:** Any changes or modifications not expressly approved by the party responsible for compliance could void the user's authority to operate this equipment.

### IMPORTANT NOTE: FCC Radiation Exposure Statement

This equipment complies with FCC radiation exposure limits set forth for an uncontrolled environment. This equipment should be installed and operated with a minimum distance of 20cm between the radiator & your body.

## **IC Warning statement**

This device contains licence-exempt transmitter(s)/receiver(s) that comply with Innovation, Science and Economic Development Canada's licence-exempt RSS(s). Operation is subject to the following two conditions:

1. This device may not cause interference.
2. This device must accept any interference, including interference that may cause undesired operation of the device.

**RF exposure statement (BT):** The equipment complies with IC Radiation exposure limits set forth for uncontrolled environments. This equipment should be installed and operated with a minimum distance of 20cm between the radiator and your body.

L'émetteur/récepteur exempt de licence contenu dans le présent appareil est conforme aux CNR d'Innovation, Sciences et Développement économique Canada applicables aux appareils radio exempts de licence. L'exploitation est autorisée aux deux conditions suivantes:

- (1) L' appareil ne doit pas produire de brouillage;
- (2) L' appareil doit accepter tout brouillage radioélectrique subi, même si le brouillage est susceptible d' en compromettre le fonctionnement.

### **Déclaration d'exposition aux radiofréquences IC:**

Cet équipement est conforme aux limites d'exposition IC établies pour un environnement non contrôlé. Cet équipement doit être installé et utilisé avec une distance minimale de 20 cm entre le radiateur et le corps.

## **CAN ICES-3 (B)/NMB-3(B) (Canada)**

This Class B digital apparatus complies with Canadian ICES-003.

## Appx. 3 Consignes de sécurité

### Sécurité générale

**AVERTISSEMENT** - Lors de l'utilisation du produit, des précautions de base doivent toujours être suivies pour éviter tout risque d'incendie, de choc électrique ou de blessure:

- Lisez toutes les instructions avant d'utiliser le produit.
- Ne l'exposez pas à des températures élevées ou à des sources de chaleur comme la lumière du soleil, le feu, les transformateurs et les radiateurs.
- N'insérez pas les doigts ou des objets étrangers dans les ports du produit.
- N'utilisez pas de produit endommagé ou modifié pour éviter les chocs électriques, les blessures, etc.
- Utilisez le produit uniquement avec des fiches et des cables intacts.
- Ne déplacez pas le produit pendant l'utilisation pour éviter tout dommage matériel interne dû aux vibrations et aux collisions.
- Manipulez le produit avec précaution pour éviter les chutes, les chocs violents ou le basculement.
- Placez le produit sur une plate-forme stable.
- Gardez le produit hors de portée des enfants et des animaux domestiques.
- évitez de submerger ou de nettoyer le produit avec des liquides.
- éteignez le produit avant tout entretien pour réduire le risque de choc électrique.
- Seuls des professionnels doivent gérer les fuites ou les défauts – demandez leur aide si nécessaire.

### Sécurité de la batterie

- Utilisez la batterie dans la plage de température spécifiée.
- Ne démontez pas, ne modifiez pas et n'endommagez pas la batterie pour éviter une fuite, une surchauffe ou un incendie.
- évitez que les bornes positives et négatives de la batterie ne se touchent ou ne touchent des objets métalliques.
- évitez de souder ou de meuler à proximité des batteries pour éviter tout incendie dû à des étincelles ou à des arcs.
- Ne laissez pas tomber d'outils métalliques sur la batterie pour éviter les étincelles ou les courts-circuits.
- Les batteries au lithium-ion présentent des risques d'incendie, alors soyez conscient de ces dangers:
  - a.L'emballage thermique peut libérer des gaz inflammables et nocifs tels que le CO et le HF. Les vapeurs provenant des batteries en feu peuvent irriter les yeux, la peau et la gorge.



- b. La concentration de ces gaz pourrait entra?ner une déflagration et une explosion .
- c. L'électrolyte de la batterie est inflammable, toxique et volatil.
- Si une batterie laisse échapper des produits chimiques ou dégage des odeurs, ne vous en approchez pas - contactez des professionnels pour une élimination en toute sécurité. Ils auront besoin d'un équipement de protection approprié.
- Ne touchez pas une batterie qui a été immergée dans l'eau pour éviter les chocs électriques. Jetez les piles usagées via les filières de recyclage appropriées.
- L'électrolyte est corrosif et peut provoquer des irritations et des brûlures chimiques. En cas de contact direct avec l'électrolyte de la batterie:
  - a. Inhalation des vapeurs: évacuer la zone contaminée, respirer immédiatement de l'air frais et consulter un médecin.
  - b. Contact avec les yeux: Rincer immédiatement les yeux à grande eau pendant au moins 15 minutes, ne pas se frotter les yeux et consulter immédiatement un médecin.
  - c. Contact avec la peau: Lavez immédiatement la zone infectée avec de l'eau et du savon et consultez immédiatement un médecin.
  - d. Ingestion: Consulter immédiatement un médecin.
- Suivez les directives locales pour une mise au rebut appropriée de la batterie; ne les brûlez jamais, ne les écrasez pas et ne les jetez jamais de manière inappropriée.

## **Personnel Précautions**

- Lorsque vous travaillez à proximité de batteries, portez des lunettes et des vêtements de protection.
- évitez de fumer, d'étincelles ou de flammes à proximité de la batterie ou du moteur.
- Dans des conditions abusives, du liquide peut s'échapper. En cas de contact, rincer à l'eau; consulter un médecin si le liquide entre en contact avec les yeux.

SAVE THESE INSTRUCTIONS



# Need Help? We're here for you!

☎ +1 800-200-2980 (Mon-Sun 9:00-17:00)

✉ [service@bluettipower.com](mailto:service@bluettipower.com)



## Sales Contact (AU)

**HANECO XERO**

1300 001 533

[info@haneco.com.au](mailto:info@haneco.com.au)

Address: 262 Marion Road,  
Netley, SA 5037 Australia

## Customer Service(AU)

Email: [sale-au@bluettipower.com](mailto:sale-au@bluettipower.com)

Address: Unit 15, 25 Gibbes Street  
Chatswood NSW 2067



@bluetti\_inc



@BLUETTI Official



@bluetti.inc



@bluetti.inc



**BLUETTI**

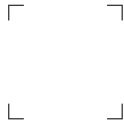

## Certificate

Inspector: \_\_\_\_\_

QC: \_\_\_\_\_

Just Power On

P/N:17.0303.0780-00A0